

Millennium LX/ST Pastry

110 • 164 • 218

Pastry display cabinets with ventilated refrigeration. One piece body with ecological polyurethane insulation (HCFC & HFC free), foamed with CO₂. Tempered glass structure. Front pyrolytic lift-up curved anti-fog glass with hydraulic pistons. Side panels in compact grade standard and anti-scratch lacquering.



LX CURVED GLASS



ST STRAIGHT GLASS

	REFRIGERANT	R404A
	ENERGY SAVING	Led + EC Fan motor
	INSTALLATION	<ul style="list-style-type: none"> • Plug-In [standard] • Remote [special order]
	PRODUCT TEMPERATURE	33.8 / 50 °F
	DEFROST	Off cycle
	CLIMATIC CLASS	3 [77 °F / 60% RH]
	REFRIGERATION	Ventilated
	CLOSING SYSTEM	Self rolling curtain

STANDARD MODEL INCLUDES:

- Operator side closure with self rolling curtain
- Work top in bright stainless steel
- Electronic control panel
- Swivel casters with brake
- Led lighting
- Side panel [2] - Color Gray E_Z065
- Front panel [Laquered finishes] - Color Gray E_Z065

COLORS

SIDE PANEL - FRONT PANEL [Standard]

Grey
E_Z065



FRONT PANEL [Special order]

Blue Cielo RAL 5005 White RAL 9003 Orange RAL 2001 Pearl Beige RAL 1035 Red RAL 3020 Lemon RAL 1032 Aluminum RAL 9006



Millennium LX/ST
Pastry

LX

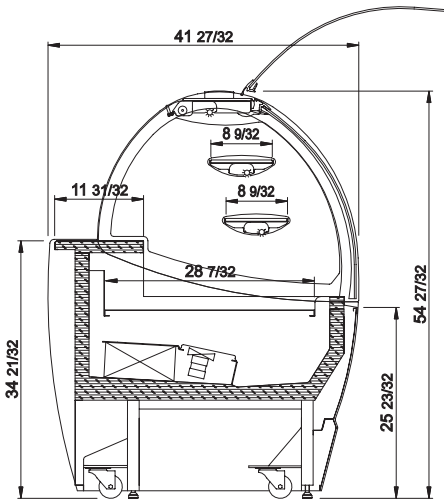

ST

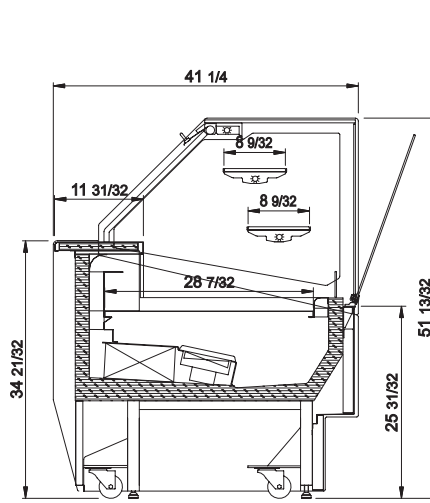

TECHNICAL FEATURES			110	164	218
External dimensions	Lenght	inch	43 7/16	64 11/16	85 15/16
Capacity	Gross / Net	liters	400 / 150	590 / 220	700 / 300
Weight	Net	lb	518	694	903
Refrigerant			R404A		
Product temperature		°F	33,8 / 50		
Compressor	Type / Q.ty		Hermetic / 1		
Defrost			Off cycle		

ELECTRICAL DATA			110	164	218
Power supply			220 / 60 / 2 pole - 3 wire grounding		
Nema plug			6-15P		
Electrical input	A		6,5	7,2	7,3

Technical info refers to models with built-in air cooled condensing unit.

PACKAGING STANDARD [Carton + Pallet]			110	164	218
External dimensions	Lenght	inch	49 1/8	70	90 3/32
	Depth x Height	inch	45 13/32 x 63 17/32		
Gross weight		lb	552	726	948

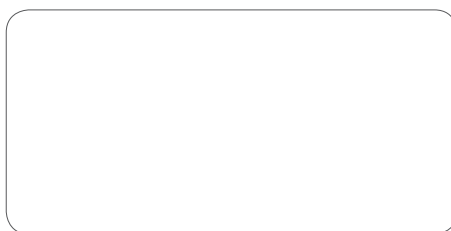

Dealer

Carpigiani North America ISA S.p.A.

3760 Industrial Drive
Winston-Salem
NC 27105
www.carpigiani-usa.com

Via Madonna di campagna, 123
06083 Bastia Umbra (PG)
Italy
T. +39 075 801 71
F. +39 075 800 09 00
E. customerservice@isaitaly.com
www.isaitaly.com