

Metrò LX/ST









Pastry

93 • 129

Pastry display cabinets with ventilated refrigeration. One piece body with ecological polyurethane insulation (HCFC & HFC free), foamed with CO₂. Tempered glass structure. Adjustable shelves. Side panels in compact grade standard and anti-scratch lacquering. Available as Grab & Go [LS] or Serve over [VA].



LX CURVED GLASS

	REFRIGERANT	R404A
	ENERGY SAVING	Led + EC Fan motor
	INSTALLATION	<ul style="list-style-type: none"> • Plug-In [standard] • Remote [special order]
	PRODUCT TEMPERATURE	<ul style="list-style-type: none"> • 30,2 / 44,6 [RV LS] °F • 30,2 / 1 [RV VA] °F
	DEFROST	Off cycle
	CLIMATIC CLASS	3 [77 °F / 60% RH]
	REFRIGERATION	Ventilated
	CLOSING SYSTEM	Doors / Sliding

STANDARD MODEL INCLUDES:

- Electronic control panel
- Swivel casters with brake
- Led lighting
- Side panel [2] - Color Gray E_Z065
- Front panel [Laquered finishes] - Color Gray E_Z065

COLORS

SIDE PANEL - FRONT PANEL [Standard]

Grey
E_Z065



FRONT PANEL [Special order]

Blue Cielo RAL 5005 White RAL 9003 Orange RAL 2001 Pearl Beige RAL 1035 Red RAL 3020 Lemon RAL 1032 Aluminum RAL 9006



ST STRAIGHT GLASS

Metrò LX/ST
Pastry

LX

N VA (SERVE OVER)

RV LS (GRAB & GO)

RV VA (SERVE OVER)

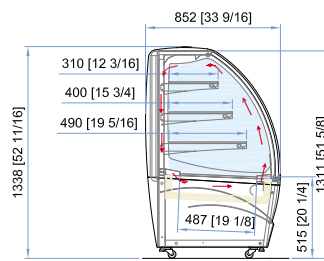
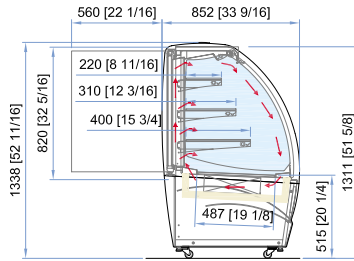
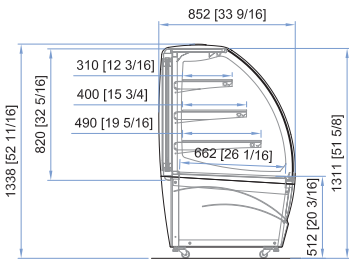

ST

N VA (SERVE OVER)

RV LS (GRAB & GO)

RV VA (SERVE OVER)

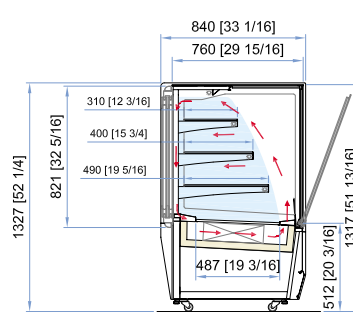
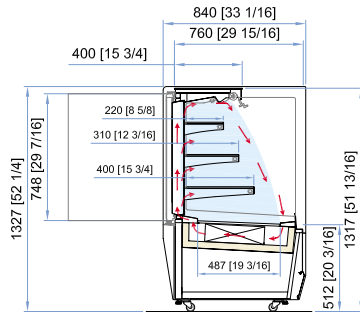
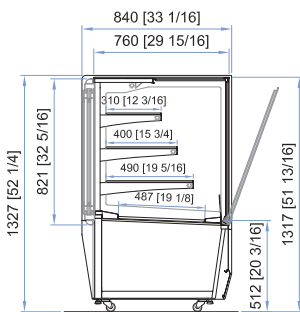

TECHNICAL FEATURES			93			129		
			N VA	RV LS	RV VA	N VA	RV LS	RV VA
External dimensions	Lenght	inch	37 13/22			51 3/8		
Capacity	Gross / Net	liters	385 / 167	385 / 125	385 / 150	535 / 233	535 / 185	535 / 210
Weight	Net	lb	440,9	683,4	727,5	551,1	881,8	948
Refrigerant			R404A			R404A		
Product temperature		°F	-	30,2 / 44,6	30,2 / 41	-	30,2 / 44,6	30,2 / 41
Compressor	Type / Q.ty		Hermetic / 1			Hermetic / 1		
Defrost			Off cycle			Off cycle		

ELECTRICAL DATA			93			129		
			N VA	RV LS	RV VA	N VA	RV LS	RV VA
Power supply			115 / 60 / 2 pole - 3 wire grounding	220 / 60 / 2 pole - 3 wire grounding	115 / 60 / 2 pole - 3 wire grounding	115 / 60 / 2 pole - 3 wire grounding	220 / 60 / 2 pole - 3 wire grounding	115 / 60 / 2 pole - 3 wire grounding
Nema plug			5-15	6-15	5-15	5-15	6-15	5-15
Electrical input	A		1	9	11,5	1	8	11,5

Technical info refers to models with built-in air cooled condensing unit.

PACKAGING STANDARD (Wooden cage)			93			129		
			N VA	RV LS	RV VA	N VA	RV LS	RV VA
External dimensions	Lenght	inch	42 5/32			55 29/32		
	Depth x Height	inch	40 x 58 15/32					
Gross weight		lb	639,4			826,7		



Dealer

Carpigiani North America ISA S.p.A.

3760 Industrial Drive
Winston-Salem
NC 27105
www.carpigiani-usa.com

Via Madonna di campagna, 123
06083 Bastia Umbra (PG)
Italy
T. +39 075 801 71
F. +39 075 800 09 00
E. customerservice@isaitaly.com
www.isaitaly.com